



**FITS
NPT & BSPT
THREADS**

**RATED
TO
150 PSI
(10 BAR)**

Turret Jet™

You can choose
the orifice size and
extension to suit your
application!

New metric tapped
balls allow use with
Extension Tubes and
Spray Tips.



UNIVERSAL COOLANT NOZZLE FOR CNC MACHINES

- Converts any NPT or BSPT hole to a fully adjustable nozzle
- Hits any target above mounting plane
- Adjusts easily for accurate coolant placement
- Difficult to accidentally knock out of adjustment
- Choose larger orifices for maximum flow
- Choose smaller orifices when using multiple nozzles
- Choose tapped ball, if you need to quickly plug the orifice (setscrew included) or to use with **Extension Tubes** (page 17) or **Spray Tips** (page 16)
- Longer extensions are a breeze to aim and shoot farther, great for Machining Centers and CNC Multi-Axis Grinders
- Choose short extensions for tight spaces like CNC Turning Centers and Screw Machines

DIMENSIONS IN INCHES (except as noted)

Part No.	Thread Size "E"	Orifice Dia. "d"	Extension "L"	A	B	C	F	Pkg Qty
TJ01605	1/16 NPT/BSPT	.086	.25	.69	.5	.44	.31	5
TJ01610	1/16 NPT/BSPT	.086	.50	.69	.5	.44	.31	5
TJ01615	1/16 NPT/BSPT	.086	1.25	.69	.5	.44	.31	5
TJ01620	1/16 NPT/BSPT	.11	0	.69	.5	.44	.31	5
TJ01625	1/16 NPT/BSPT	.11	.25	.69	.5	.44	.31	5
TJ01630	1/16 NPT/BSPT	.11	.5	.69	.5	.44	.31	5
TJ01635	1/16 NPT/BSPT	.11	1.25	.69	.5	.44	.31	5
TJ01640	1/16 NPT/BSPT	.16	0	.69	.5	.44	.31	5
TJ01645	1/16 NPT/BSPT	M4 x .7	0	.69	.5	.44	.31	5
TJ00100	1/8 NPT/BSPT	.11	0	.82	.63	.50	.38	5
TJ00130	1/8 NPT/BSPT	.11	.25	.82	.63	.50	.38	5
TJ00131	1/8 NPT/BSPT	.11	.50	.82	.63	.50	.38	5
TJ00132	1/8 NPT/BSPT	.11	1.25	.82	.63	.50	.38	5
TJ00134	1/8 NPT/BSPT	.16	0	.82	.63	.50	.38	5
TJ00136	1/8 NPT/BSPT	.16	.50	.82	.63	.50	.38	5
TJ00138	1/8 NPT/BSPT	.16	1.25	.82	.63	.50	.38	5
TJ00141	1/8 NPT/BSPT	M5 x .8	0	.82	.63	.50	.38	5
TJ00142	1/4 NPT/BSPT	.11	0	.94	.75	.63	.44	5
TJ00144	1/4 NPT/BSPT	.11	.25	.94	.75	.63	.44	5
TJ00145	1/4 NPT/BSPT	.11	.50	.94	.75	.63	.44	5
TJ00146	1/4 NPT/BSPT	.11	1.25	.94	.75	.63	.44	5
TJ00101	1/4 NPT/BSPT	.16	0	.94	.75	.63	.44	5
TJ00148	1/4 NPT/BSPT	.16	.50	.94	.75	.63	.44	5
TJ00150	1/4 NPT/BSPT	.16	1.25	.94	.75	.63	.44	5
TJ00153	1/4 NPT/BSPT	M5 x .8	0	.94	.75	.63	.44	5
TJ00166	3/8 NPT/BSPT	.11	0	1.13	.88	.75	.50	5
TJ00170	3/8 NPT/BSPT	.11	1.25	1.13	.88	.75	.50	5
TJ00154	3/8 NPT/BSPT	.16	0	1.13	.88	.75	.50	5
TJ00156	3/8 NPT/BSPT	.16	.50	1.13	.88	.75	.50	5
TJ00158	3/8 NPT/BSPT	.16	1.25	1.13	.88	.75	.50	5
TJ00102	3/8 NPT/BSPT	.22	0	1.13	.88	.75	.50	5
TJ00160	3/8 NPT/BSPT	.22	.50	1.13	.88	.75	.50	5
TJ00162	3/8 NPT/BSPT	.22	1.25	1.13	.88	.75	.50	5
TJ00165	3/8 NPT/BSPT	M6 x 1.0	0	1.13	.88	.75	.50	5

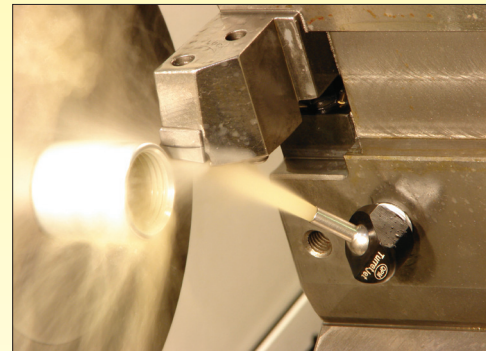
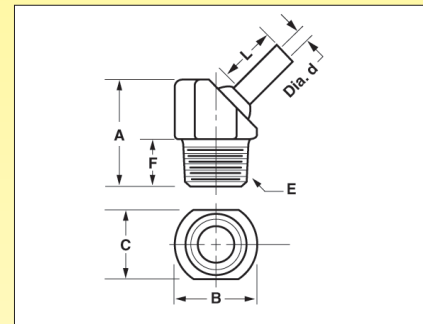

TurretJets are ideal for CNC Turning Centers, Machining Centers, Screw Machines and CNC Multi-Axis Grinders.

Material: Body: Acetal **Ball & Extension:** Stainless Steel
Maximum Pressure: 150 PSI (10 bar) **Maximum Operating Temperature:** 160°F (70°C)

WE RESERVE THE RIGHT TO CHANGE SPECIFICATIONS WITHOUT NOTICE OR OBLIGATION.